

New **S T R**
New Thyristor Regulator

Seroun Electronics Co., Ltd

151B-6L, Namdong Ind. Complex, Gojandong 722,
Namdongku, Incheon, Korea, 405-310
Tel : 032-821-4901~3, Fax : 032-821-4904
e-mail : seroun@hanafos.com
<http://www.seroun.co.kr>

C O N T E N T S

- [1] Introduction
- [2] Model Identification
- [3] Basic Specification
- [4] Function & Features
- [5] Application
- [6] Outline Drawing & Size
- [7] Terminals & Connection
 - [7]-1 Connection for Three phase Unit
 - [7]-2 Connection for Single phase Unit
 - [7]-3 Notes for connection of terminals
- [8] Operation
 - [8]-1 Pre-Inspection & Confirmation
 - [8]-2 Operation & Function of Key
 - [8]-3 Parameter Setting Procedure
 - [8]-4 E/MSG(Error Message)
 - [8]-5 Setting of Input Signal & Output Mode
 - [8]-6 Selection/Setting/Release of E/MSG
 - [8]-7 Assurance of Input & Output at "Operation Mode"
 - [8]-8 Operation Procedure
- [9] Capacity Table for Selection of Unit

[1] Introduction

This new model **Thyristor Regulator(New STR)**, which is designed and produced to the highest standards and most advanced technologies in industry, is also a technology-condensed one so as to be able to call a next generation product as for the Thyristor Regulator, and further so as to be able to change the usual concept of it. There are various kinds of model such as the plastic case type-A,B,C which is applied in low capacity Unit, and while the steel case type which is applied in high capacity Unit. And also this new Model has a great advantage as the User can select the proper type among CC-type (Constant Current type), CV-type(Constant Voltage type), CP-type(Constant Power Type) and ZC-type(Zero-Crossing type). And the parameter change can be done by a simple touch of key on key board. Furthermore because the cooling efficiency is maximized by using the epochal improved heat sink, the Unit becomes smaller, lighter and economical much more than the existing Unit in the world. Especially the molded control parts of the plastic case type can make the Unit perform a more stable and safe operation at any surroundings.

[2] Model Identification

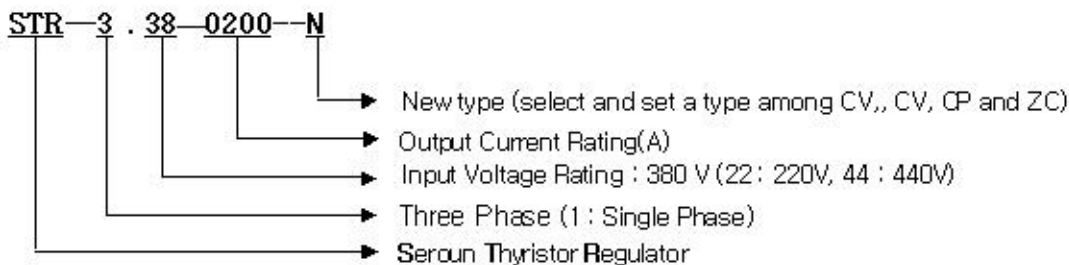

[3] Basic Specification

Input Voltage Rating	• AC220V • AC380 • 440V Frequency : 50~60 Hz	Allowable Isolation	• DC 1500V for one minute between case & case, and case & earth terminal
Allowable Input Voltage	• ±11% of Input Volt Rating	Output Range	• 0~100%
Control power	• Lower than 5 W	Control Method	• Phase Control and Cycle Control
Order Input Method	• Digital	Control Signal	• DC 4~20 mA, DC 0~5V, DC 0~10V
Communication	• Degree : EIA	Installation	• Installation in indoor panel
• The communication mode are an option specification, When you place order, please make sure the inquired specification			

[4] Major Function & Features

• Mode-Selective Function between Phase and Cycle Control	• Error Message-Selective Setting and Release Function
• The Control by Program-embedded CPU	• Type-Selective Function(types are CC, CV, CP and Zero-Crossing type)
• Communication Function by RS485(under preparation)	• Perfect Linear PID Control is achievable
• Multi Output-Selective Display Function(display Ampere, Voltage, KW and KWh etc)	• Effective Value Control(Every displayed value on segment is an Effective Value)

[5] Application

• R.F furnace	• Hydrogenation furnace	• Tunnel furnace
• Melting furnace	• Sintering furnace	• Annealing furnace
• Dehydrogenation furnace	• Ion nitriding furnace	• Polymer melting heater
• Vacuum furnace	• Fluidizing furnace	• Painting dryer
• Hot air dryer	• Calcination furnace	• Salt bath heater
• Infrared furnace	• Water heater	

[6] Size & Outline Drawing

[6-1] Three Phase Unit

Capacity(A)	mm	H	W	D	W1	H1	Remarks	
25A		85	120	165	110	45	plastic case-C type (Including heat sink)	
35A, 40A, 50A, 60A, 70A, 90A		320	130	230	90	280	steel case type	
110A, 130A, 150A		370	150	230	105	330		
200A, 250A		440	165	230	130	390		
300A, 350A, 400A, 450A		500	250	230	180	450		
Higher than 500A		Customer's Specification						

[6-2] Single Phase Unit

Capacity(A)	mm	H	W	D	W1	H1	Remarks	
25A, 35A, 40A, 50A		85	120	165	110	45	plastic case-C type (Including heat sink)	
60A, 70A, 90A, 110A, 130A, 150A, 200A		320	130	230	90	280	steel case type	
250A, 300A, 350A, 400A, 450A		370	150	230	105	330		
Higher than 500A		Customer's Specification						

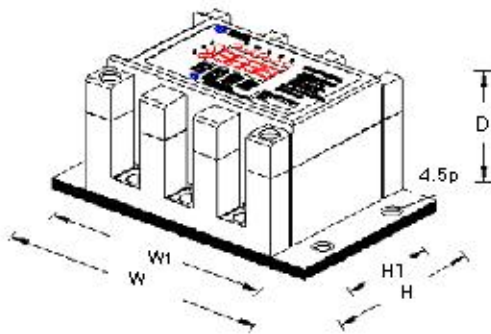

Plastic case-B

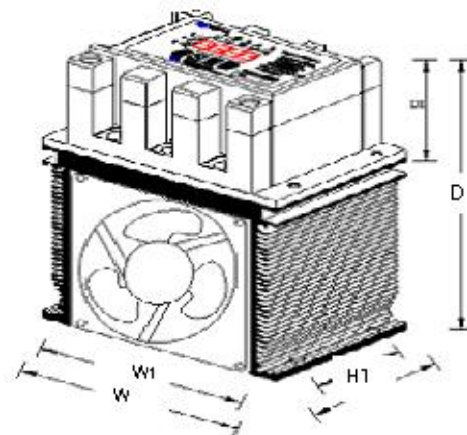

Plastic case-C

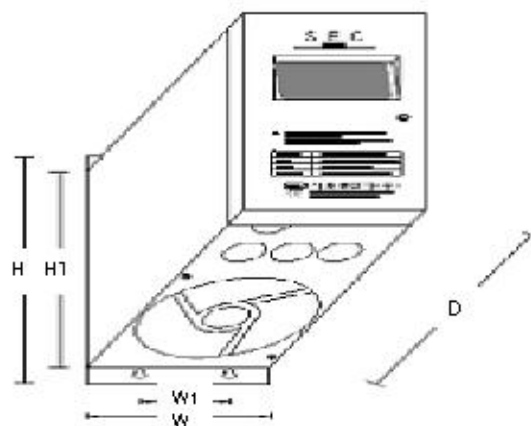

Steel case type

[7] Terminals & Connection

[7]-1 : Three Phase(3P) STR-Unit

[7]-1 -1 : Plastic Case-220V/380V/440V, 25A only

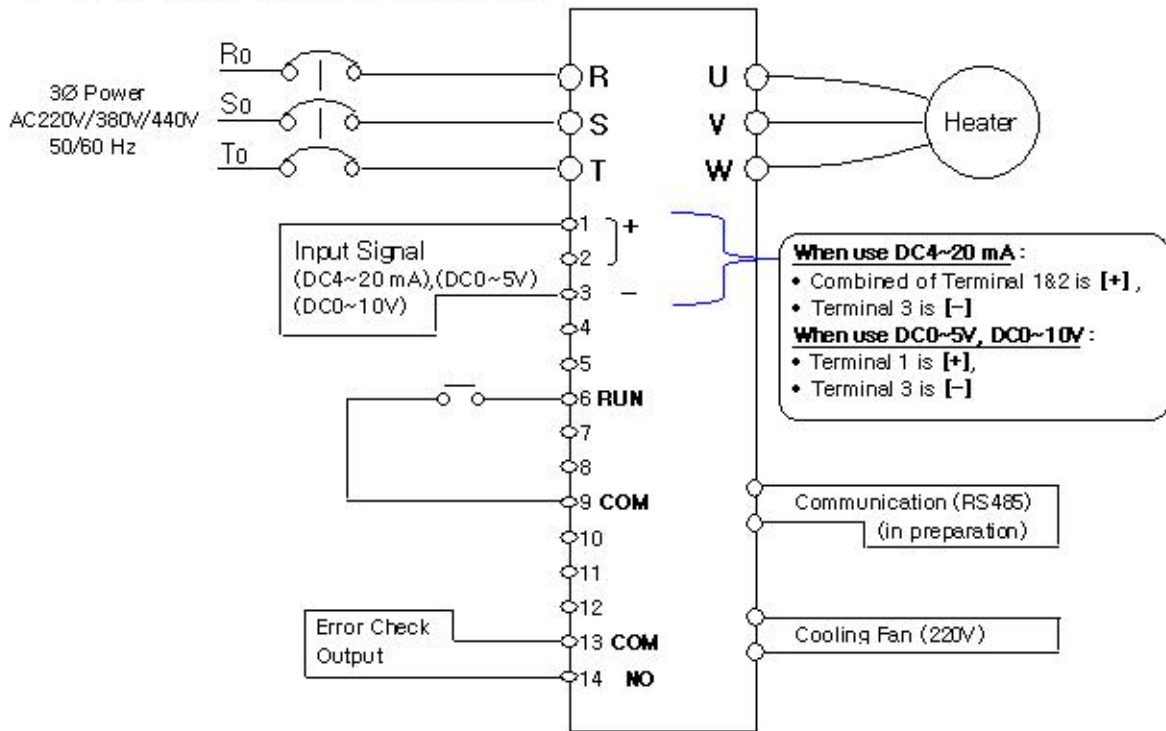

[7]-1 -2 : Steel Case-220V, 35A or higher

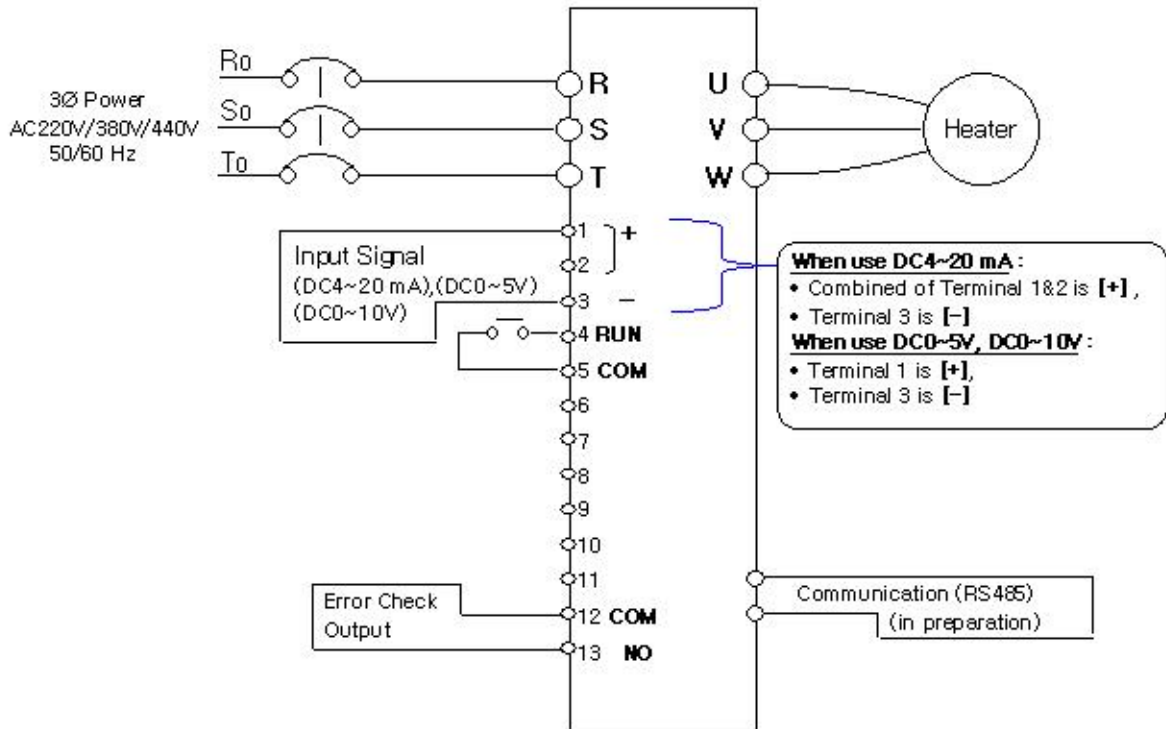

[7]-1 -3 : Steel Case-380V/440V, 35A or higher

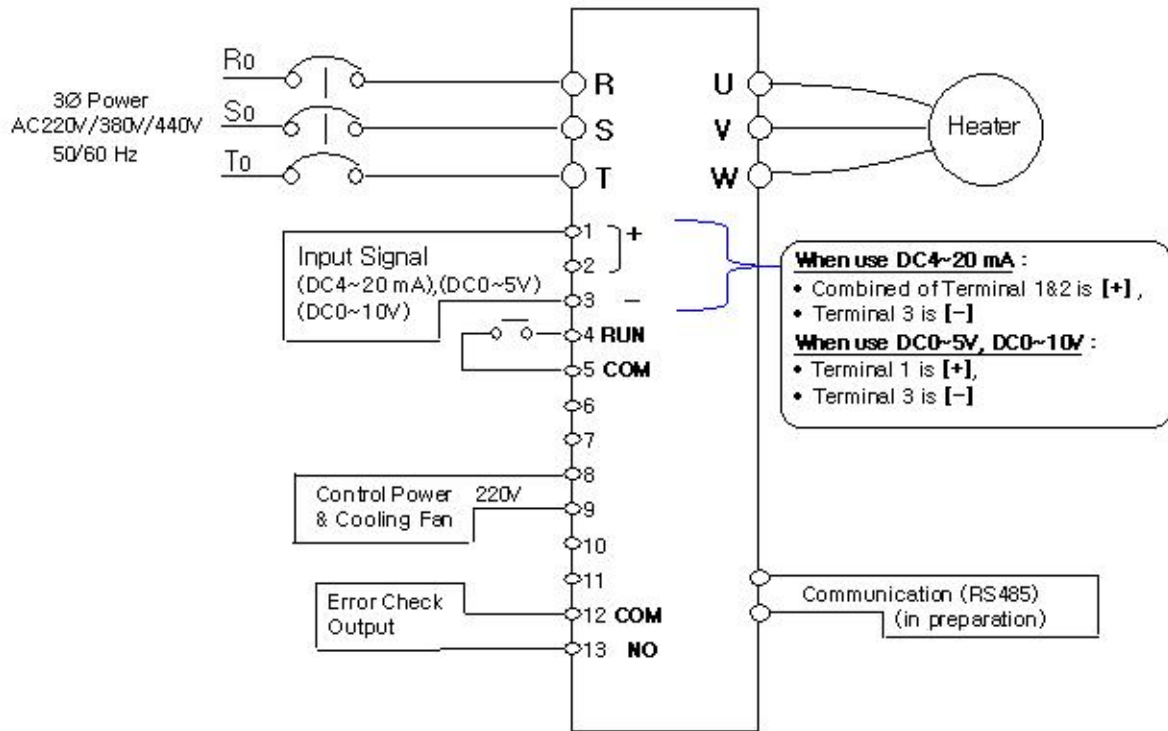

[7]-2 : Single Phase(IP) STR-Unit

[7]-2 -1 : Plastic Case-220V/380V/440V, 50A or lower

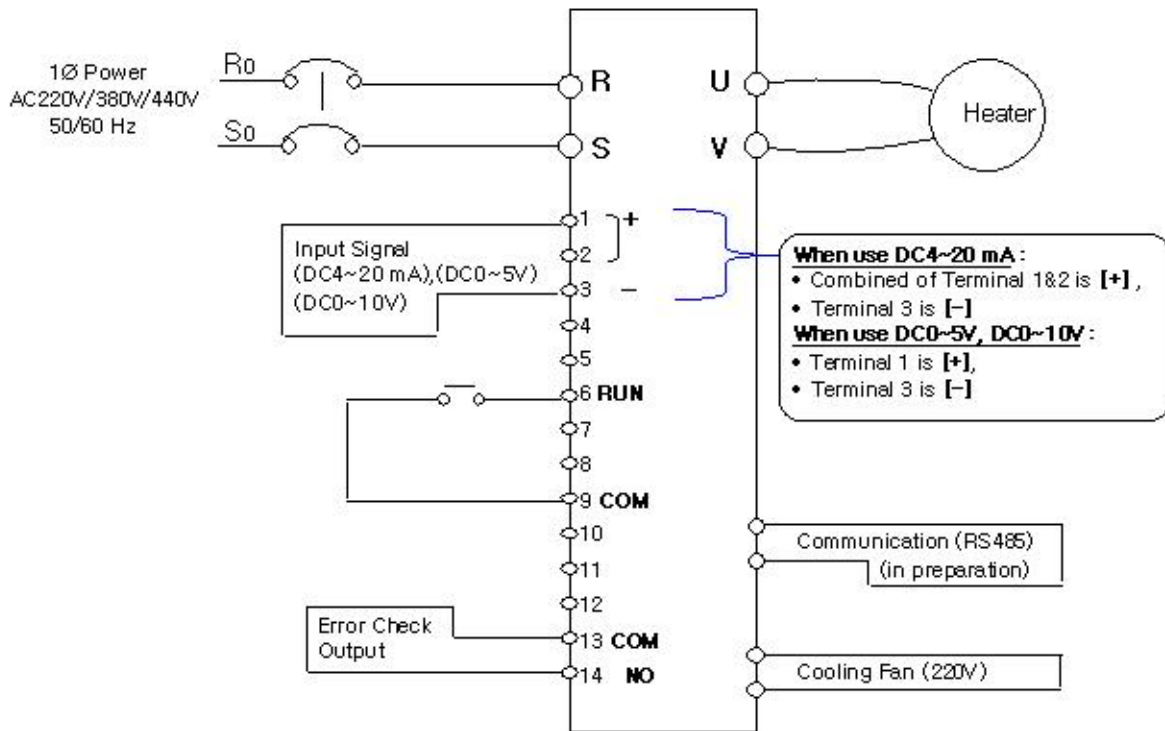

[7]-2 -2 : Steel Case-220V, 60A or higher

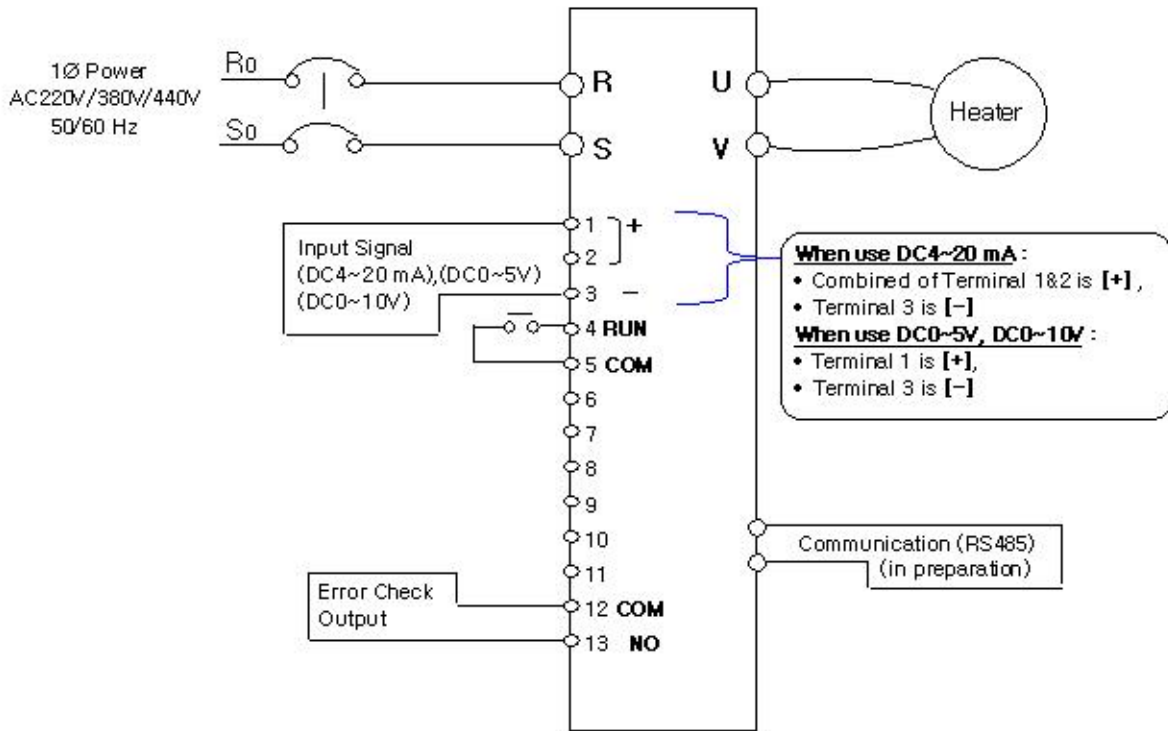

[7]-2 -3 : Steel Case-380V/440V, 60A or higher

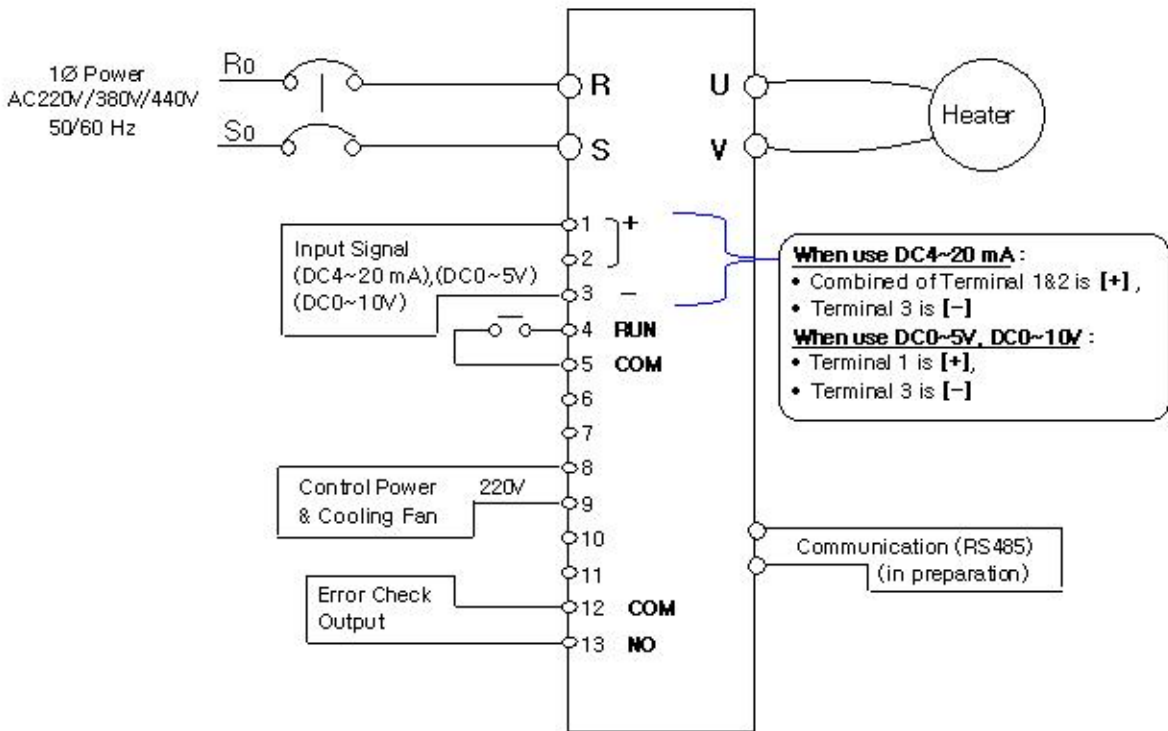

[7]-3 Notes for connection of terminals

1. To protect the Unit from malfunctioning by noise, the connecting cable of the Control Circuit Terminal No. are recommended to use a Twist Shield and Twist Pair Shield type.
2. And in case customer want to use 'RUN" terminal to install the "RUN Switch" on the main pane, and to use this "Run Switch", the "PW On/Off Switch" of the Unit must be run off.

3. How to Run On/Off of the Unit :

- To Run Off the Unit, Push the "Mode Key" and "Down Key" at same time.
- To Run On the Unit, push the "Mode Key" and "Up Key" at same time.

4. The connecting cable length should be less 50m.
5. The connecting cable should be sufficiently thick in consideration of a voltage drop and terminal size.

[8] Operation

[8]-1. Pre-inspection and Confirmation :

Prior to installation of the Unit, please inspect the Unit and confirm as below.



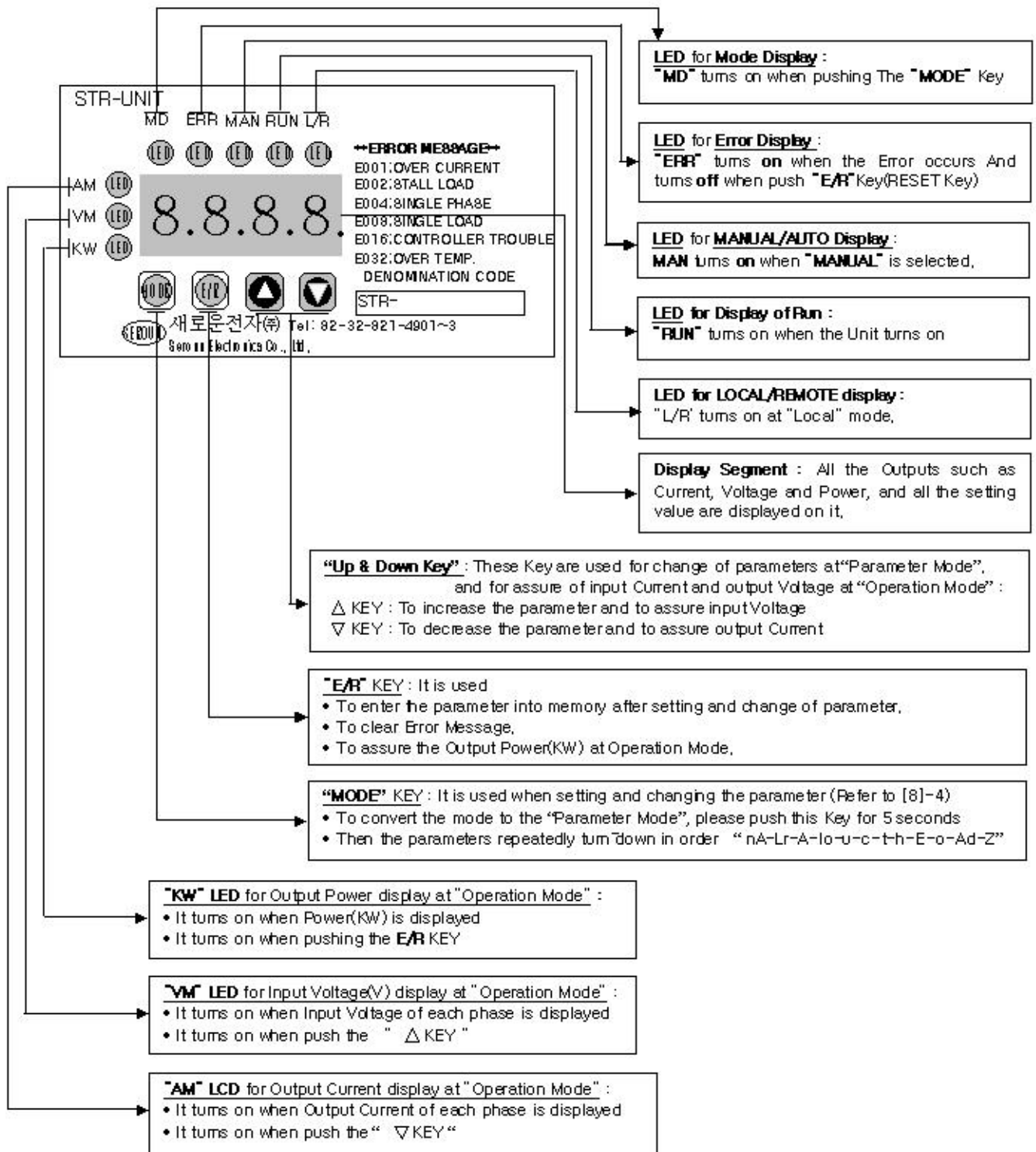

1. Check if it is fully complied with the ordered specifications, mainly for the input voltage and current rating, and the capacity.
2. Check if there is any damaged parts or not in the Unit and please tighten the loosened bolts
@Please note that some damages may happen on the way of delivery.
3. Whenever the Unit is installed inside the panel of the heater, it is recommendable to install the fan to exhaust the air from the panel box of the heater so as to keep the Unit at proper temperature and humidity
4. Be careful of SCR and circuit not to be damaged by an improper connection and isolation of the Unit.
5. Please check if the actual output current and the displayed current are same or not.
6. Please check if the output current of each phase is in balance or not.
If it's unbalance is higher than 20%, please let us know.

[8]-2. Operation Panel and Function of Key Board

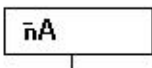

[8]-3. Parameter Setting Procedure

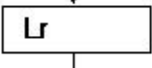
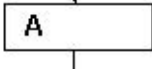
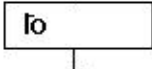
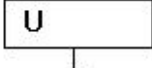
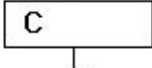
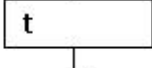
Push this  (Mode Key) for five(5) seconds, then start to set or change the parameters at "Parameter Mode" as order as below

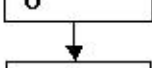
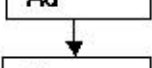
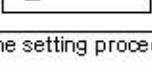
Parameter Symbol	Parameter's Name	Setting Method	Range of setting	Ex. of setting
	◆ Manual/Auto : Selection of "Manual" or "Auto", @001 : "Manual", 000 : "Auto"	1, Use   Key to increase or decrease the value 2, Whenever moving to next parameter please push the "Mode" Key	By user	"Auto" nA000
	◆ Local/Remote : Selection "Local" of "Remote" @001 : "Local", 000 : "Remote"		By user	"Local" Lr001
	◆ Ampere Limit : Restriction of Output Current at Constant Current Mode(CC)		0~999A	80A A080
	◆ Signal Input & Output : Selection of Control Signal Mode		@ Refer to [8]-5	4~20mA* at CP Mode Io02
	◆ Voltage Limit : Restriction of Output Voltage at Constant Voltage Mode(CV)		0~999V	380V U380
	◆ Current Rating(A) of Motor ; @ User is prohibited to change the Setting.		0~999A	90A C090
	◆ Soft Time : Setting of the Soft Time		0~999sec	10초 t010
	◆ Setting of Frequency : Selection & Setting Frequency		50 hz or 60 hz	60hz h060
	◆ Error Message : Setting of the Error Message		@ Refer to [8]-6, nextpage	
	◆ Output of Power : Output power Restriction at Constant Power Mode"(CP)		0~999 Kw	20 KW o020
	◆ Address : Address of Unit for 485 communication		0~99	Ad96
	◆ Zero-Crossing : Setting of Frequency at Zero-Crossing Mode		60~999 Hz	120 Hz Z120

The setting procedure for All the Parameters is completed by pushing this  Key (Enter Key)

Then pushing this  (Mode Key) for 5 seconds, the "Parameter Mode" is returned to "Operation Mode"

[8]-4. E/MSG (Error Message)

- E001 : Over-Current at Output (this message not selective, Whenever Over-Current occurs, output stops)
- E002 : Stall Load(it alarms on when output current is higher than three times of current rating)
- E004 : Single Phase(it alarms on when any of input power source is lost)
- E008 : Single Load(it alarms on when any output unbalance in between phases is higher than 30 % of an average output of phases)
- E032 : Over-Temperature(it alarms on when the temperature of heatsink surface is higher than 85[°C])

[8]-5. Setting of Input Signal & Output Mode

Input Signal(I)	Output Mode(O)	Ex. Setting	Remarks
0 : 4~20 mA	0 : Constant Current(CC)	fo00	4~20mA Signal at CC mode
	1 : Constant Voltage(CV)	fo01	4~20mA Signal at CV mode
	2 : Constant Power(CP)	fo02	4~20mA Signal at CP mode
	3 : Zero-Crossing(ZC)	fo03	4~20mA Signal at ZC mode
1 : 0~5 V	0 : Constant Current(CC)	fo10	0~5V Signal at CC mode
	1 : Constant Voltage(CV)	fo11	0~5V Signal at CV mode
	2 : Constant Power(CP)	fo12	0~5V Signal at CP mode
	3 : Zero-Crossing(ZC)	fo13	0~5V Signal at ZC mode
2 : 0~10 V	0 : Constant Current(CC)	fo20	0~10V Signal at CC mode
	1 : Constant Voltage(CV)	fo21	0~10V Signal at CV mode
	2 : Constant Power(CP)	fo22	0~10V Signal at CP mode
	3 : Zero-Crossing(ZC)	fo23	0~10V Signal at ZC mode

[8]-6. Selection, Setting and Release of E/MSG

Selection of E/MSG	Ex. of setting	Status of Action	Remarks
Over-Current	E001	It is not selective, Whenever Over-Current occurs, output stops	
When set all the E/MSG at same time	E000	Every E/MSG actuale	<ul style="list-style-type: none"> • When E/MSG actuale, output stops • When E/MSG do not actuale, output continues
When release all the E/MSG at same time	E255	Every E/MSG does not actuale	
When set required E/MSG	E254	E001(Over-Current Message) actuale	
When set multiple E/MSG			
Ex : When want to set E001 & E002	E252	E001 & E002 actuale	
When want to set E001 & E004	E250	E001 & E004 actuale	
When want to set E001 & E008	E246	E001 & E008 actuale	
When want to set E001 & E032	E222	E001 & E032 actuale	
When want to set E008 & E032	E215	E008 & E032 actuale	

E001 : Over-Current at Output (this message is not selective, Whenever Over-Current occurs, output stops)

E002 : Stall Load(it alarms on when output current is higher than three times of current rating)

E004 : Single Phase(it alarms on when any of input power source is lost)

E008 : Single Load(it alarms on when any output unbalance in between phases is higher than 30 % of an average output of phases)

E032 : Over-Temperature(it alarms on when the temperature of heat sink surface is higher than 85[°C])

[8]-7. Assurance of Input & Output at "Operation Mode"

1. At "Operation Mode" pushing  Key, LCD lamps turn on, at same time related Input & Output is displayed on the segment and is repeated in order as below.

- **S** : display "Set Value"(SV)
- **P** : display "Process Value"(PV)
- When **VM** Lamp turns on
- When **AM** Lamp turns on
- **O** : display "Output Power"

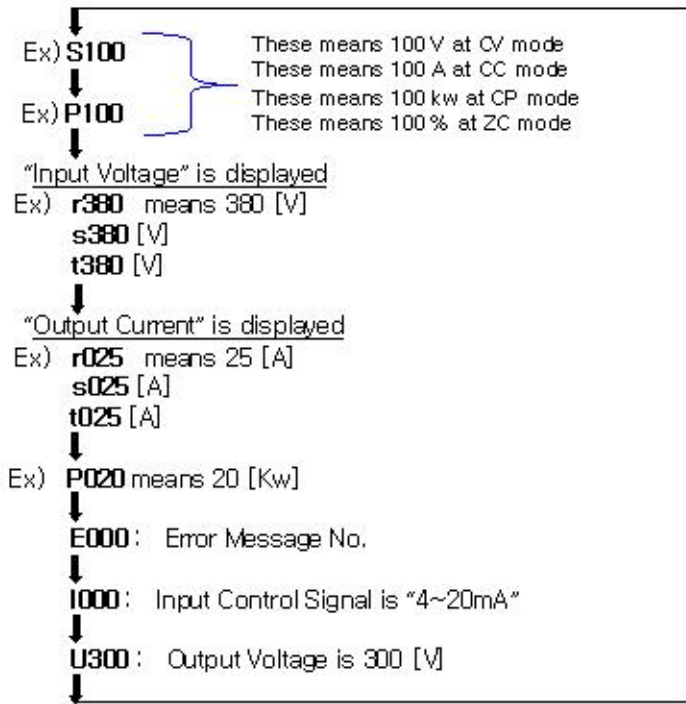

2. When pushing  Key, SV and PV is displayed on segment as below

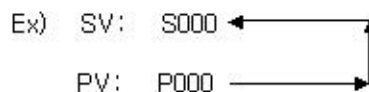

3. When pushing  Key, **VM**Lamp turns on, then Input Voltage is displayed on segment as below

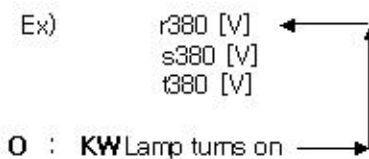

4. When pushing  Key, **AM** Lamp turns on, then Output Current is displayed on segment as below

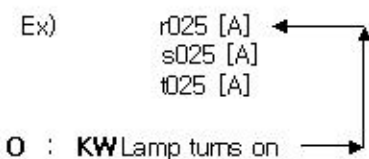

At Manual Mode

When S000 is Displayed on segment, Up and Down Key are used as below

- This Up-Key is used to increase SV,

- This Down Key is used to decrease SV

[8]-8 Operation Procedure

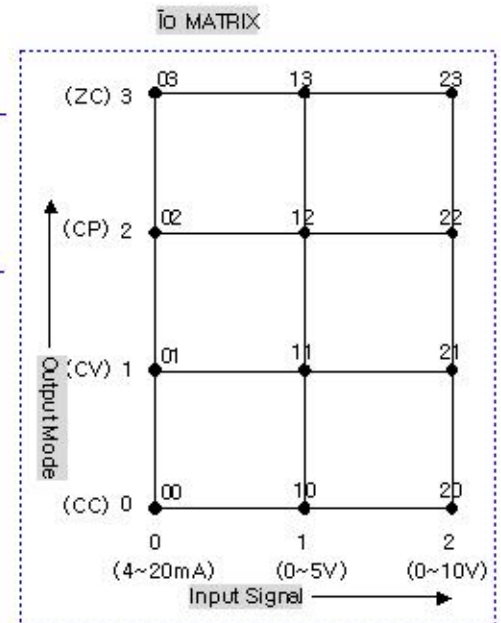
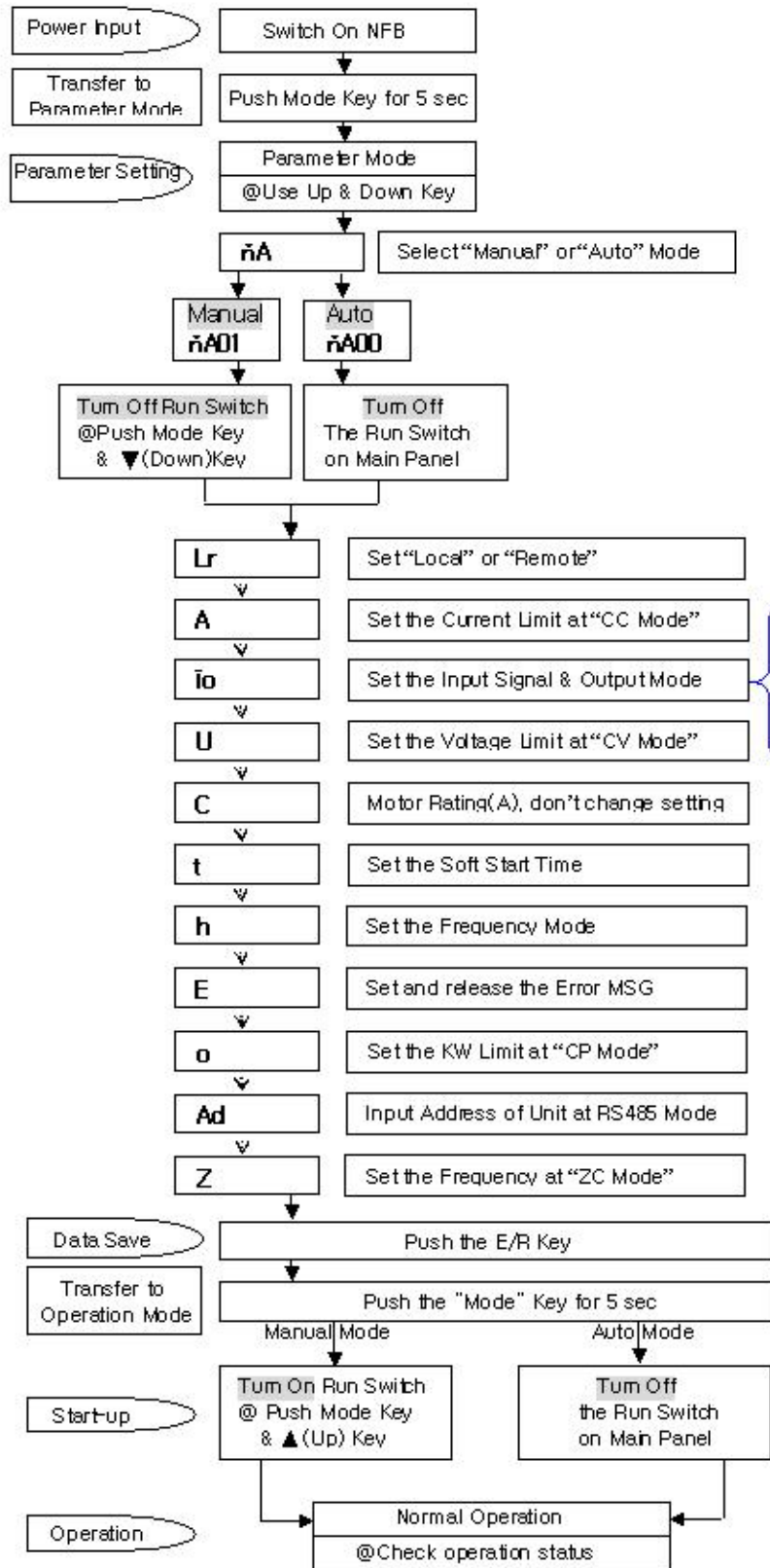

[9] Capacity table with selection Guide

• Capacity table

Single Phase					Three Phase				
220 V		380 V & 440 V			220 V		380 V & 440 V		
Current(A)	KW	Current(A)	380 V	440 V	Current(A)	KW	Current(A)	380 V	440 V
			KW	KW				KW	KW
25	5,5	25	9,5	11	25	9,5	25	16	19
35	7,7	35	13	15	35	13	35	23	26
40	8,8	40	15	17	40	15	40	26	30
50	11	50	19	22	50	19	50	33	38
60	13	60	22	26	60	22	60	39	46
70	15	70	26	30	70	26	70	46	53
90	20	90	34	39	90	34	90	59	68
110	24	110	42	48	110	42	110	72	84
130	29	130	49	57	130	49	130	85	99
150	33	150	57	66	150	57	150	98	114
200	44	200	76	88	200	76	200	131	152
250	55	250	95	110	250	95	250	164	190
300	66	300	114	132	300	114	300	197	228
350	77	350	133	154	350	133	350	230	266
400	88	400	152	176	400	152	400	263	304
450	99	450	171	198	450	171	450	295	342
500	110	500	190	220	500	190	500	328	380
600	132	600	228	262	600	228	600	394	456
800	176	800	304	352	800	304	800	525	608
1000	220	1000	380	440	1000	381	1000	658	762

• Selection guide

- A. In case the Load is a Resistive, capacity of the Unit should be higher than that of the Load by 20~25%
- B. In case the Load is a Inductive, capacity of the Unit should be higher than that of the Load by min. 40~50%