

Products guide-Old Model-Jan. 2009 updated

SEROUN

Old Model **SMC-UNIT**
Motor Soft Starter

SEROUN ELECTRONICS CO., LTD

151B-6L, Namdong Ind. Complex, Gojan-Dong 722,

Namdong-Ku, Incheon, Korea

Tel: 82-032-821-4901/3 Fax: 82-032-821-4904

e-mail: serowun@chol.com, seroun@hanafos.com

www.serou.co.kr

SEROUN.s SMC-UNIT

SEROUN's Motor Soft Starter (SMC-UNIT) is designed and assembled to the highest standards which is most suitable for the Realization of Energy Saving, the Maximization of Efficiency with a safe operation and a maximization of machine life, eliminating the Peak Current which is occurred during the move of the machines. And also this SMC-UNIT can minimize the maintenance cost because it adopts Forward/Reverse Mode controlled by a semiconductor switch. Furthermore it is easiest to operate all of the parameters, digitizing all the function and composing of a dialogue type control menu which are displayed on the Segment on it.

Model Identification

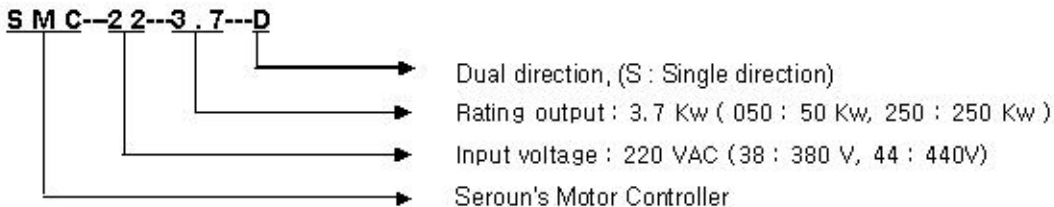

Basic specification of the Unit

Application	Induction Motor of : • Hoist & Crane • Transportation Vehicle • Fan & Blower • Pump & Mixer
Input voltage	• 3 Ø AC 220V/380V/440V (±10%)
Frequency	• 50 and 60 Hz
Ampere Rating	• 0~Cap (A)
Ambient.	• Temp.: -20~85 [°C], Humidity : RH : below 90 % (w/o dew)
Installation	• Indoor (dust , oil and corrosive gas free)
Method of Move	• Soft Start and Stop
Cooling	• Below 60 [°C]: self-cooling, • Higher than 60 [°C] : fan cooling
Alarm	• O.C (Over- Current) • O.V (Over-Voltage)

Characteristics of SMC-Unit

- The soft starter makes the motor start up smoothly by alleviating the initial surge current at the start-up of the motor;
- The soft starter makes the motor stop smoothly at its shutdown by using DC injection braking.
- The soft starter makes the motor stop instantly and smoothly by dynamic brake and keep it on hold;
- The forward and reverse rotating of a motor can be smoothly alternated by the semiconductor switch free of a friction-the one otherwise to be caused by a large surge current into the motor as the motor changes direction ;
- The soft starter displays the real time current and the processing time on its display,
- The accelerating time, the brake time, the brake delay time, the offset value, the brake voltage, the hold voltage, the current rating, the energy saving value, the parameter, and the error factors can be set into the soft starter,.
- The current into the motor is under check all the time by the soft starter and an abnormal current, if any, is checked out and stopped momentarily by the dynamic brake.

Confirmation and Inspection

Prior to installing the Unit, please inspect the Unit and confirm as below.

- Check if it is fully complied with the ordered specifications, mainly for the input voltage and current rating, and the capacity.
 - Check if there is any damaged parts in the Unit.
- @Please note that some damages may happen on the way of delivery.

Operation of the Unit

Control of key

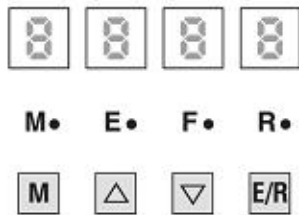

DISPLAY → LEFT ONE : MODE
 RIGHT 3 MODES: PARAMETER VALUE

LED → M : MODE E : ERROR
 F : FORWARD R : REVERSE

Function of Key

It has 4 Keys, 4 Segment Displays and 4 LED on the panel of Unit as below.



- M Key** : Pushing it , Mode repeats in order of ;
 "SETd → A → b → d → o → u → h → p → C → E → SETd"
- ▲ Key** : Pushing it, Data Value decreases by 1 per each push, and if lasting for 1 sec or longer
 Data Value decreases in high speed.
- ▼ Key** : Pushing it Data Value increases by 1 per each each push , and if lasting for 1 sec or longer
 Data Value increases in high speed.
- E/R Key** : it saves Data and reset Errors

- M LED** : LED turns on by pushing this Mode Key
- E LED** : LED turns on when Errors
- F LED** : LED turns on when Motor runs Forward.
- R LED** : LED turns on when Motor runs Reverse.

@ Where

A : Accel Time	: 0~99.9 sec.
b : Brake Time	: 0~9.9 sec.
d : Brake Delay Time	: 0~9.9 sec.
o : Offset	: 0~99 %.
u : Brake Voltage	: 0~55 %.
h : Hold Voltage	: 0~50 %.
C : Current Rating	: 0~200 A.
E : Energy Saving	: 0~100 %

P : Parameter

- P000 : Time Delay Hold off and Current Display OFF.
- P001 : Time Delay Hold on and Current Display OFF.
- P002 : Current Display on and Hold OFF.
- P003 : Current Display on and Hold ON.
- P008 : Energy Saving, Time Display Hold OFF and Current Display Hold OFF.
- P009 : Energy Saving, Time Display Hold ON and Current Display Hold OFF.
- P010 : Energy Saving, Current ON and Hold OFF.
- P011 : Energy Saving, Current ON and Hold ON.

E : Error Message.

- E001 : Activates when R, S, T shortened.
- E002 : Activates when Over-Current than 700 % of Rating at Full section.
- E003 ; Activates when Over-Current than 400 % of Rating at Run section.
- E004 ; Activates when Over-Current than 400 % of Rating for 2 sec or longer at section of Accel and Brake.
- E005 : Activates when Over-Current than 200 % of Rating for 4 min or longer at Run section.
- E006 : Activates when Over-Current than 120 % of Rating for 8 min or longer at Run section.
- E007 ; THR when Over-Temperature

Terminal Layout

② Connection of control terminals

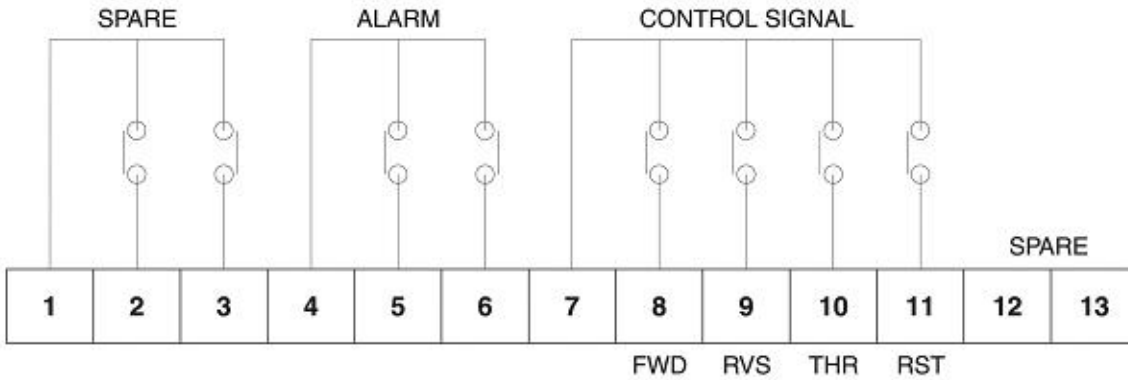

③ Illustration of Terminals

No	Abbreviation	Term	Function
1~3			SPARE
4	COM 1	COMMON	Common Input
5	NO	NORMAL OPEN	Output, ON when errors
6	NC	NORMAL CLOSE	Output, OFF when errors
7	COM 2	COMMON	Common Input(digital)
8	FWD	FORWARD	Forward running
9	RVS	REVERSE	Backward running
10	THR	THERMAL	Contact of motor over-temperature sensor
11	RST	RESET	Reset contact
12~13			SPARE

Standard Connection

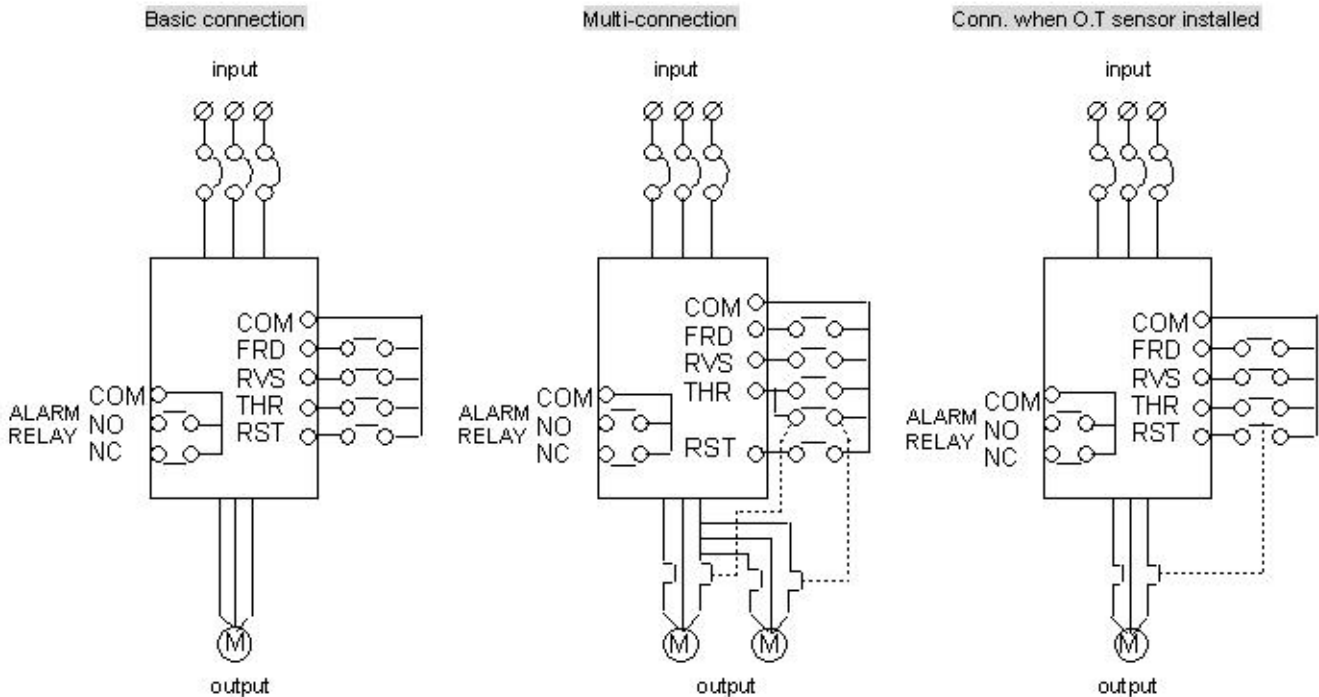

Illustration of Display

Display	Display of Time	Display of Current
REAd	Ready to run motor	Ready to run motor
A000	Accel. Time when move Forward/Reverse	Accel. Current when move Forward/Reverse
run0	run0 Time	run0 Current
b000	Brake Time at Forward/Reverse	Brake Current at Forward/Reverse
d000	Brake Delay Time	Brake Delay Current
hold	Hold Time	Hold Current

Block Diagram

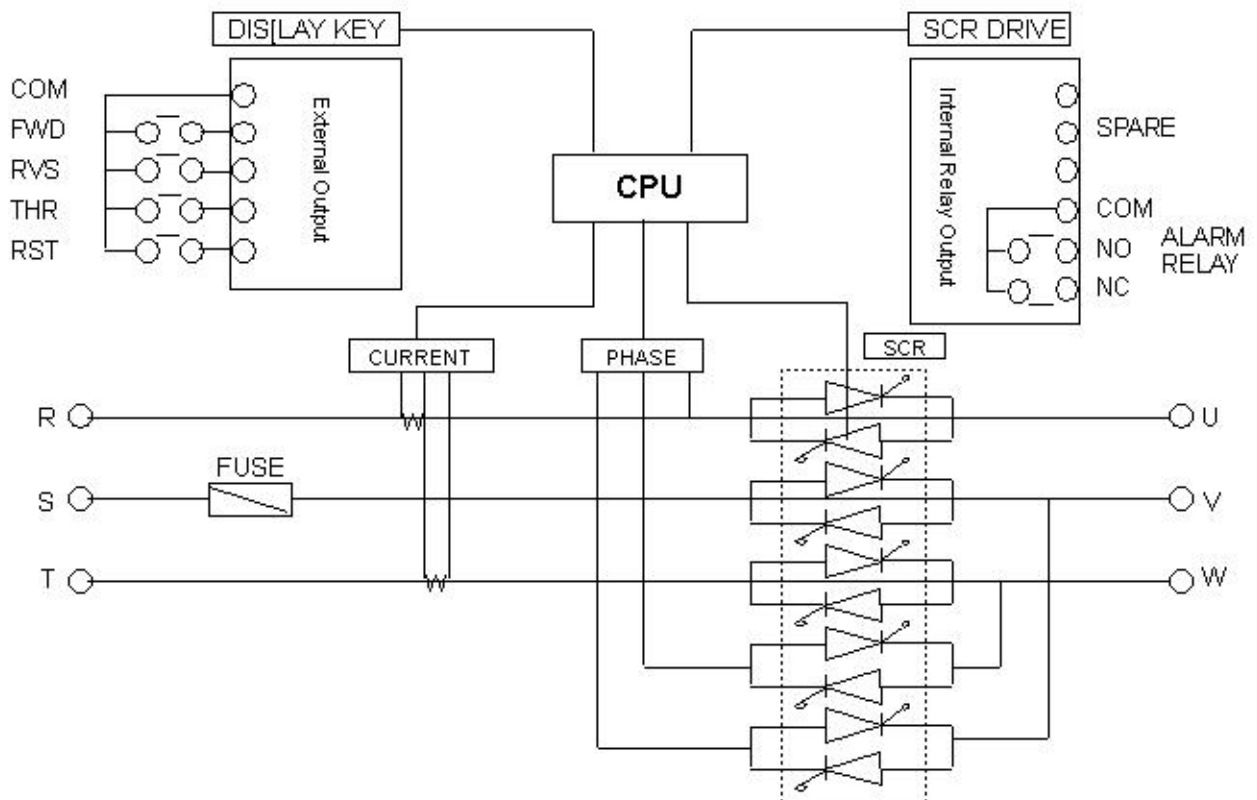
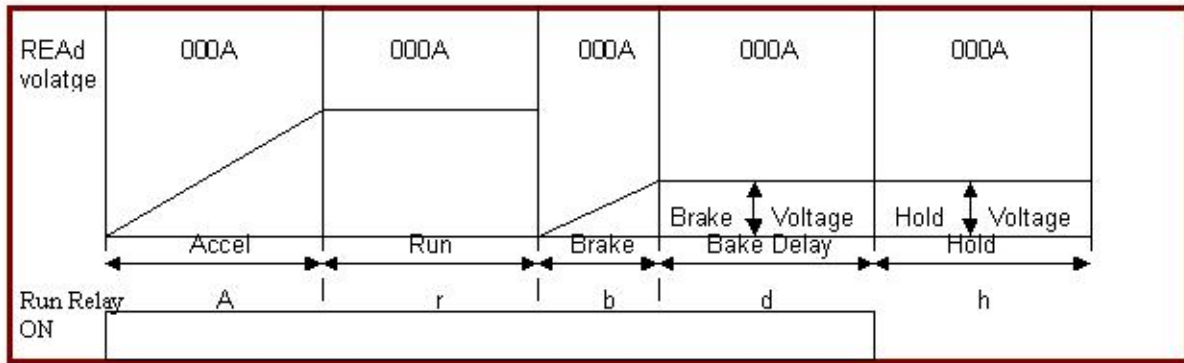
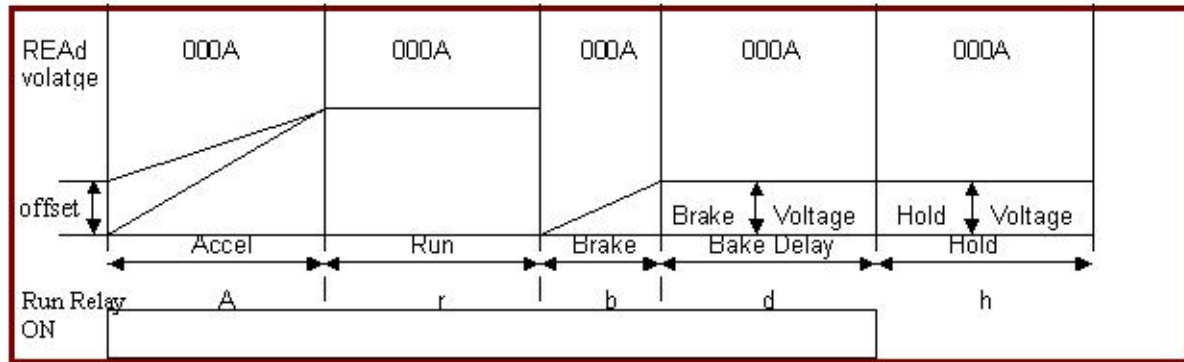

Diagram of Display

⊙ **Display of Current**



⊙ **Display of Current (at Offset)**



⊙ **Display of Time**

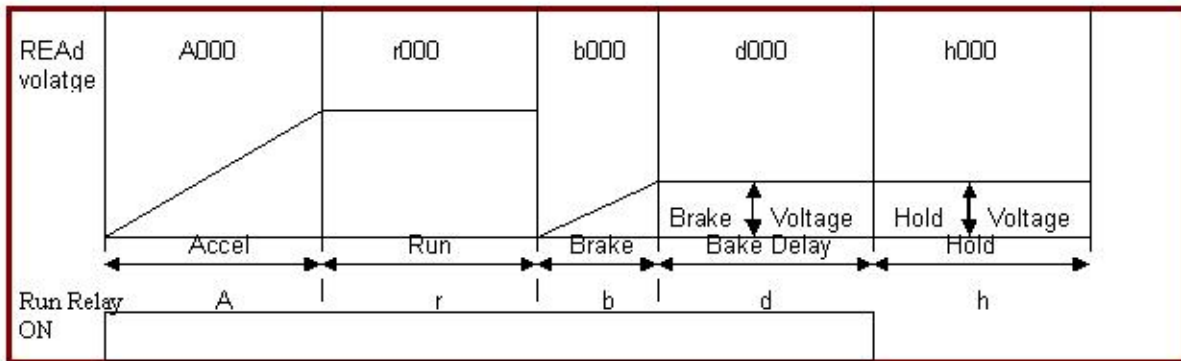

⊙ **Display of Time (at Offset)**

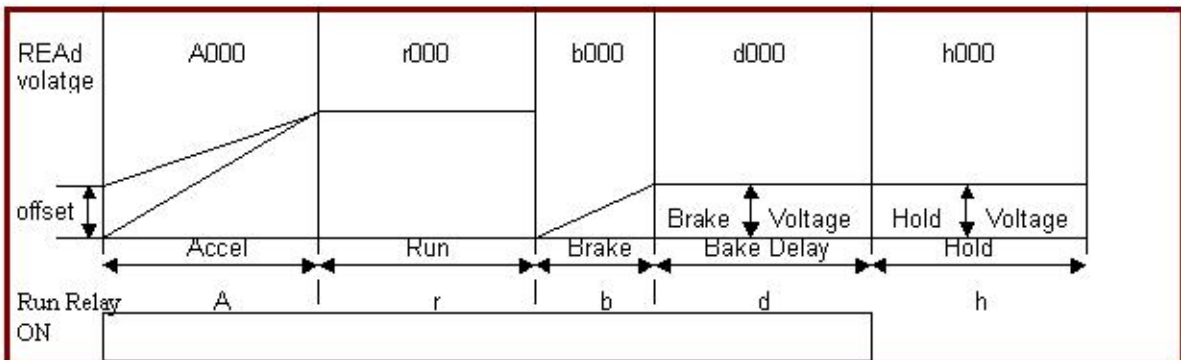

⊗ Display of Data Input

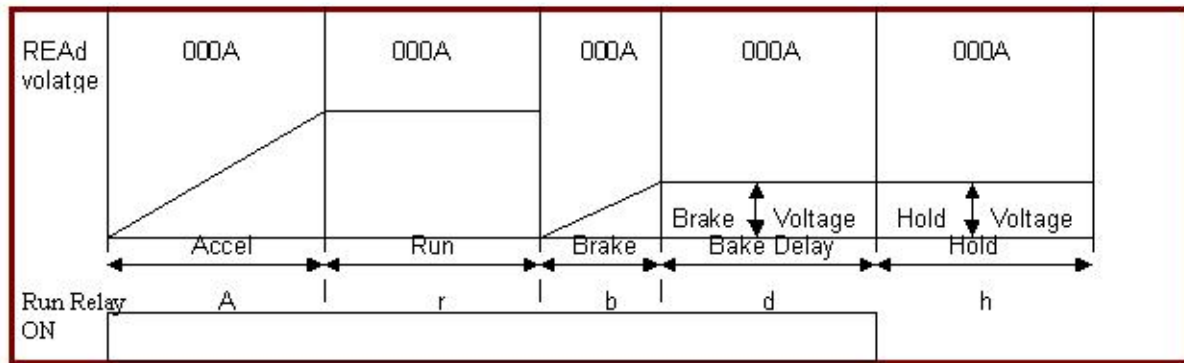

Example for Display

Mode	Key input	Term	Data input
A	0 4 0	Accel. Time	Set Accel. Time at 4.0 sec.
b	0 2 0	Brake Time	Set Brake Time at 2.0 sec.(if unnecessary set at 0.1)
d	0 1 0	Brake Delay Time	Set Brake Delay Time at 1 sec.
o	0 1 5	Offset	Set initial Move Voltage at 15 %
u	0 3 5	Brake Voltage	Set Brake Voltage at 35 %
h	0 3 0	Hold Voltage	Set Hold Voltage at 30 %
p	0 0 1	Parameter	0: Hold Off Time 1: Hold On Time 2: Hold Off Current 3: Hold On Current
C	0 0 7	Rating Current	Ex.) Current Rating is 7A at 440V and 3.7Kw
S	E t D	Set Data	It does not input Data
E	9 0 0	Energy Saving	Ex) 10 % Energy Saving.

@ Current Rating of Motor must be input on Mode 'C'

Product specification

● AC 220V-single & dual direction

● AC 380/440V-single & dual direction

classification model	capacity (Kw)	current rating(A)	classification model	capacity (KW)	Current rating(A)	
					380V	440V
SMC-22-2.2	2.2	7	SMC -38/44-2.2	2.2	4	4
SMC-22-3.7	3.7	12	SMC -38/44-3.7	3.7	7	6
SMC-22-5.6	5.6	18	SMC -38/44-5.6	5.6	10	8
SMC -22-7.5	7.5	25	SMC -38/44-7.5	7.5	14	12
SMC -22-011	11	36	SMC -38/44-011	11	20	18
SMC -22-015	15	50	SMC -38/44-015	15	28	24
SMC -22-018	18	60	SMC -38/44-018	18	34	29
SMC -22-022	22	72	SMC -38/44-022	22	42	36
SMC -22-030	30	98	SMC -38/44-030	30	57	50
SMC -22-037	37	122	SMC -38/44-037	37	70	60
SMC -22-045	45	148	SMC -38/44-045	45	85	70
SMC -22-055	55	180	SMC -38/44-055	55	105	90
SMC -22-075	75	247	SMC -38/44-075	75	142	123
SMC -22-090	90	300	SMC -38/44-090	90	170	150
SMC -22-110	110	360	SMC -38/44-110	110	210	180
SMC -22-130	130	430	SMC -38/44-130	130	250	216
SMC -22-160	160	530	SMC -38/44-160	160	305	262
SMC -22-180	180	610	SMC -38/44-180	180	345	292
SMC -22-200	200	660	SMC -38/44-200	200	380	320
SMC -22-250	250	820	SMC -38/44-250	250	475	410
SMC -22-300	300	980	SMC -38/44-300	300	580	500

@ Others on customer's specification

structure

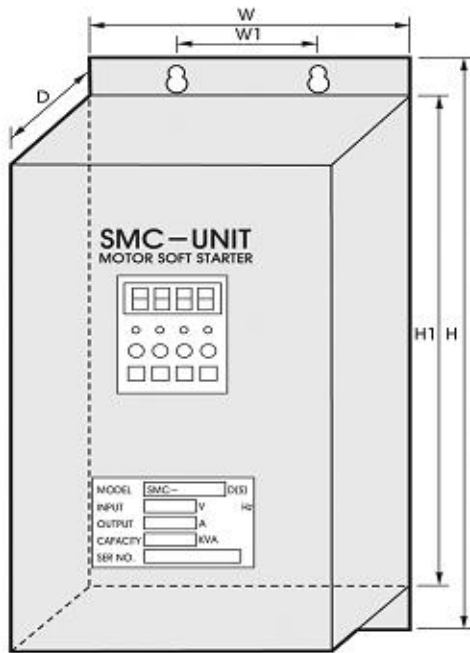

size

(220V/380V/440V)

Rev.3(05/02)

Size(mm) current (A)	H	H1	W	W1	D
~40	350	290	200	120	170
~60	380	320	200	120	220
70~250	510	450	270	200	255
~550	560	500	307	225	285
600A or higher	on customer's specification				

@This specs can be varied by Design change and Modification