

SEROUN

THYRISTOR REGULATOR

General Type **STR-UNIT**

Seroun Electronics Co., Ltd.

151B-6L, Namdong Ind. Complex,
Kojandong 722, Namdongku, Incheon, Korea.
Tel : 82-32-821-4901~3, Fax : 82-32-821-4904
e-mail : serowun@chol.com, seroun@hanafos.com

CONTENTS

☆	Seroun's Thyristor Regulator -----	3
☆	Model Identification -----	3
☆	Basic Specification -----	3
☆	General Characteristics -----	3
☆	Overall Inspection -----	4
☆	Major Function of the Unit -----	4
☆	Operating Instruction -----	5
☆	Three Phase Unit -----	7
	· Structure and Size-----	7
	· Control Parts and Function-----	7
	· Troubleshooting-----	9
	· Standard Connection-----	10
	· Block Diagram-----	10
☆	Single Phase Unit -----	11
	· Structure and Size-----	11
	· Control Parts and Function (~50A)-----	12
	· Control Parts and Function (60A~)-----	12
	· Special Function-----	13
	· Troubleshooting-----	13
	· Standard Connection-----	14
	· Block Diagram-----	14

The SEROUN Thyristor Regurator(STR-Unit) is designed and assembled to the highest standards And technologies in the industry for single phase and three phase load application. Since STR Unit features compactness and lightweight, high density of mounting in an instrumentation panel is possible.

Two model of STR-Unit, based on the phase control system, are available. One is the **General Type** which is a conventional voltage control model, the other is the **New Type** with a display segment on the Unit, which customer can select the various operation modes, such as the constant voltage(CV-type), the constant current(CC-type) and the constant power(CP-type) and the Zero Crossing(ZC-type), and the control signal mode among DC4-20mA, DC0-5V and DC0-10V, and the frequency mode between 60Hz and 50Hz, so with its excellent operating performance and reliability, an ideal type can be selected according to the property of the heating element of the electric furnace heater and can be exerted effectively to customer' satisfaction.

Model Identification

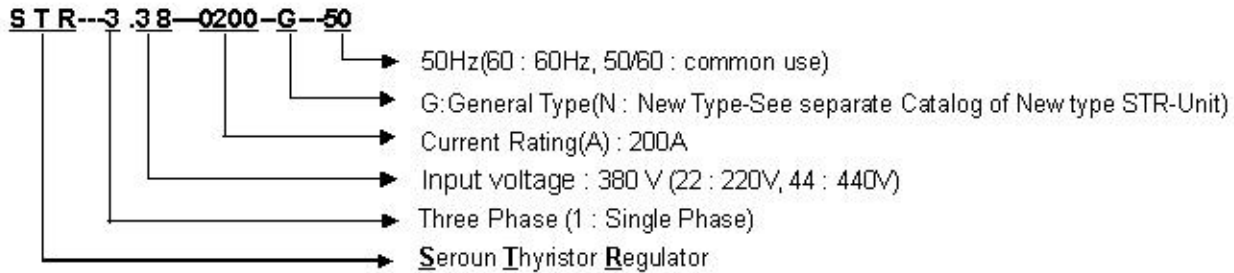

Basic Specifications of STR-Unit

Type	• Three Phase(3) STR • Single Phase(1)STR.
Application	• Heater control.
Input voltage	• 220/380/440V. • Others: on customer's specs.
Frequency	• 50 and 60 Hz. @ Single Phase Unit adopts the combined use.
Current	• 25, 35, 40, 60, 70, 90, 110, 150, 200, 250, 300, 350, 400, 500, 600, 800 AND 1000A. or higher
Ambient	• -20~60 [°C], Humidity: RH: lower than 90% (without dew).
Load	• Heater: resistive • Transformer: inductive
Control	• Phase Control (Local/Remote operation).
Control input	• Current input signal: 4~20mA(250Ω). @ input signal :1-5V may be used instead TIC4-20mA
Output range	• 0~100 % .
Driving range	• 0~100 %
Alarm	• At over-current : OC • At heater cut and the high load among phases : SL • At fuse intercepted : SL • At high temperature. of the heat sink. : OT
Start	• Soft start time 0~300 seconds(Standard : 10 sec
Cooling	• Fan cooling : 90 A or higher for single phase unit and 60 A or higher for three phase unit. • Others : Natural cooling
Isolation	• 220V: 2000V • 380/440v: 2500V at short of main circuit
Isolation Resistance	• 10 MΩ (DC 500V MEGGER)

General Characteristics

- It can be achievable a permanent operation because it has a non-contact different from a magnet type..
- It can precisely control the temperature it has the high speed feedback.
- It can perform the fully automatic temperature control by its easy and continuous electronic program control.
- There is no electrical hazard because of complete safety protection system.
- It is not only compact than a conventional version but increases the feedback speed and ripple ratio because of composing of bi-directional SCR.
- Because the control parts is located on the operation panel of the Unit, it can be achievable an easy operation.
- It alarms at the high heat sink temperature by installing temperature sensor on the surface of the heat sink.
@ Temperature sensor is not applied to the single phase Unit. So It is recommendable to install the exhaust fan inside the panel of the heater

Overall Inspection

Confirmation

Prior to installation of the Unit, please inspect the Unit and confirm as below

- Check if it is fully complied with the ordered specifications, mainly for the input voltage and current rating, and the capacity.
- Check if there is any damaged parts in the Unit.

@Please note that some damages may happen on the way of delivery.

Cautions

- Whenever the Unit is installed inside the panel of the heater, it is recommendable to install the fan to exhaust the air from the panel box of the heater so as to keeping the Unit at proper temperature and humidity
- Be careful of High Speed Fuse or SCR of the Unit not to be damaged by an improper connection and isolation between the Unit and the heater, and between the phases of the heater.
- Uniform load distribution is mandatory. When the load unbalance between phases exceeds 30 % S.L LED illuminates.
- Check if the input voltage is normal prior to switching on the Unit.

Major Function of the Unit

Function of Over- Current Detection

The Unit adopts a Over Current Detection Relay (EOCR) which its range is set by LOADAMP volume. When the current higher than this setting value flows to the heater, EOCR activates and stops the gate signal to turn off the Unit. And at same time it make O.C LED illuminate by activating the Alarm Circuit. In order to restore the Unit, please push the Reset Button after restoring all the faults causing LED illuminated.

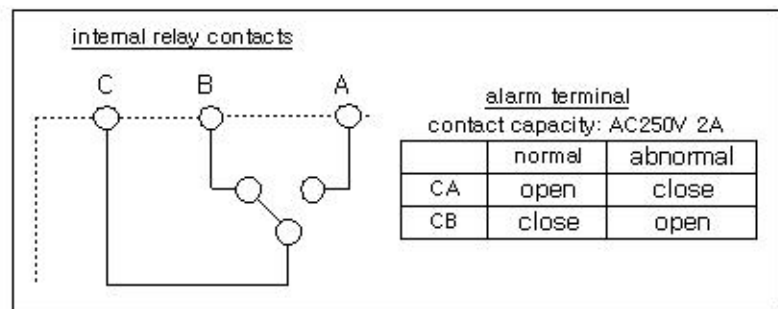
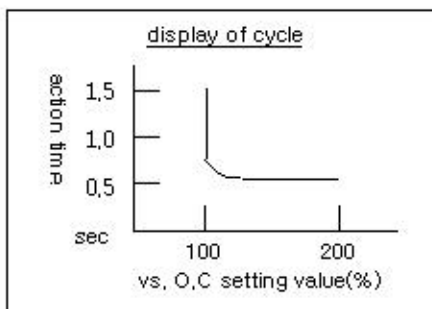

@A proper setting of LOADAMP volume do completely protect the SCR and heater from the damage by over-current..

Function of maximum load setting

The heater load can be set by MAXAMP volume and be automatically and safely controlled without any increase of the heater load. Further it has Local / Remote control function.

Alarming Function at Input power failure and heater failure

In case the heater failure by an incorrect connection of the heater, alarm illuminates.

S.P LED does at input power failure by high speed fuse intercepted, while SL LED does at heater load failure by the short or open of the heater.

Soft Start Function

The Unit is free from the flicker phenomena at the output by managing the momentary peak current to the

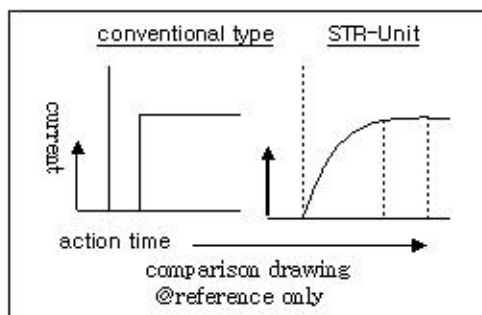

transformer and by controlling very softly even at high heater load.

The Soft Start Time is fixed at 10 seconds to protect SCR of the Unit and heater from damage.

⊗ **High temperature alarm function for the heat sink**

The temperature sensor on the heat sink surface detects a abnormal high temperature of the heat sink activates the O.T alarm Circuit.

Operating Instructions

1. Check the Unit and Heater before Operation

- 1.1. Check if there is any incorrect connection or damage in the heater and tighten bolts/nuts loosened.
- 1.2. Check if there is any insufficient isolation between phases of the Unit and of heater.
- 1.3. Check if there is any insufficient or damaged isolation between the output and case of the **Unit**.
- 1.4. Check if the input voltage of the Unit complies with that of the ordered specification.

2. Preset the control panel of the Unit before Operation

- 2.1. Set the Auto/Hand selection switch at "Hand".
- 2.2. Set the Local/Remote selection switch at "Local".
- 2.3. Leave the "Run" contact terminal in the terminal block on the operation panel of the **Unit** opened.

But when the customer wants to turn on or off the heater with the Power Switch on the panel of the heater, get the this "Run" contact terminal connected with the Power Switch on the panel of the heater.

- 2.4. Set the PW(Power) On/Off selection switch at "Off".
- 2.5. Set MAXAMP volume at minimum.
- 2.6. Set the LOADAMP initial volume at maximum position.
Note: This is to prevent lower current causing O.C LED illuminated during operation.

- 2.7. Turn on the relevant NFB(Non- Fuse Breaker) inside the panel of the heater.
- 2.8. If want to remote control the heater load outside the **Unit**, install a B10K Ω volume on the panel of the heater and connect it with the "VR" terminal on the **Unit**.

Note1: Setting of LOADAMP volume : When the heater reaches at full load, decrease the LOADAMP volume slowly until O.C LED starts to illuminate. The current value at just when O.C LED starts to illuminate, is called the " O.C Norm"

Note2: At the Remote Mode Operation, MAXAMP volume becomes idle.

3. Operation

There are four Operation Modes starting from " 2. Preset the control panel of the Unit before operation" above.

3-1 "Hand-Local" Mode Operation

- 3.1.2. Set the Hand/Auto selection switch at the "Hand" and Local/Remote selection switch at the "Local" on the control panel of the **Unit**.

Note: In case of 1(single) phase **unit** of 50A or less, get the terminal No.15 and No.16 closed each other for the Hand mode operation and also the terminal No.3 and No.4 closed each other for the Local mode operation.

- 3.1.3. Turn on the power On/Off selection switch on the control panel of the **Unit** or turn on the power switch on the panel of the heater.
- 3.1.4. Increase slowly the MAXAMP volume from the set minimum level to the level where a full heater load can be attained.
- 3.1.5. Make sure that the input voltage and output voltage of the **Unit** be same when the MAXAMP volume reaches at the maximum.
- 3.1.6. When the heater is normalized at a full load, start setting the O.C (over current) parameter by adjusting the LOADAMP volume on the control panel of the **Unit**.
Decrease slowly the LOADAMP volume from the preset level until O.C LED starts to illuminate and stop there. And increase again and set at the level 10% higher than the "Norm" at where this LED starts to illuminate.

3.2 'Hand-Remote' Mode Operation

- 3.2.1. Start setting the Hand-Remote mode operation.
- 3.2.2. Set the Hand/Auto selection switch at the "Hand" and the Local/Remote selection switch at the "Remote" on the control panel of the **Unit**.
Note: In case of 1(single) phase **Unit** of 50A or less, get the terminal No.15 and No.16 closed each other for the Hand mode operation, and also get the terminal No.4 and No.5 closed each other for the

Remote mode operation.

3.2.3. Refer to the Clause 3.1.3 above.

3.2.4. Keep the VR contact terminal connected with the B10K Ω volume on the panel of the heater.

3.2.5. Set and control the heater load with the B10K Ω volume(function is same as the MAXAMP volume at Hand-Local mode operation)

3.2.6. Refer to the Clause 3.1.7. above.

3.2.7. When the power switch or B10K Ω volume is not available on the panel of the heater or the existing B10K Ω volume is malfunctioning, change the operation mode over Hand-Local mode operation.

3.3. "Auto-Local " Mode Operation

3.3.1 Start setting the Auto-Local mode operation.

3.3.2. Set the Auto/ Hand selection switch at the "Auto" and Local/Remote selection switch at The "Local" on the control panel of the Unit.

Note: In case of 1(single) phase Unit of 50A or less, get the terminal No.14 and No.15 closed each other for the Auto mode operation and also the terminal No.3 and No.4 closed each other for the Local mode operation.

3.3.3. Refer to the Clause 3.1.3 above

3.3.4. Make sure that TIC4~20mA signal cable from the panel of the Heater is correctly connected with(+) and (-) terminals at the terminal block on the Unit.

3.3.5. Set the MAXAMP Volume on the control panel of the Unit at the maximum or the required load.

3.3.6. Refer to the Clause 3.1.7. above

3.3.7. The **Unit** works by the current signal from TIC4~20mA on the panel of the heater to keep the heater automatically running.

3.4. " Auto-Remote" Mode Operation

3.4.1. Start setting the Hand-Remote mode operation.

3.4.2. Set the Auto/Hand selection switch at Auto and Local/Remote selection switch at the Remote.

Note: In case of 1(single) phase Unit of 50A or less, get the terminal No.14 and No.15 closed each other for the Auto mode operation and also get the terminal No.4 and No.5 closed each other for the Remote mode operation.

3.4.3. Refer to the Clause 3.1.3 above

3.4.4. Make sure that TIC4~20mA signal cable from the panel of the Heater is correctly connected with(+) and (-) terminals at the terminal block on the Unit.

3.4.5. Set the B10 $\kappa\Omega$ volume on the panel of the heater at the maximum or required heater load.

3.4.6. Refer to the Clause 3.1.7. above

3.4.7. The Unit works by the current signal from TIC4~20mA on the panel of the heater to keep the heater automatically running.

3.4.8. When the power switch or B10K Ω volume is not available on the panel of the heater or the existing B10K Ω volume is malfunctioning, change the operation mode over Hand-Local mode operation.

Remark : When the Temperature deviation between the set temperature of TIC and actual temperature exceeds 5 [°C],, perform an auto-tuning in accordance with TIC manufacturer's instruction.

3 (Three Phase)STR-Unit

Structure and Size

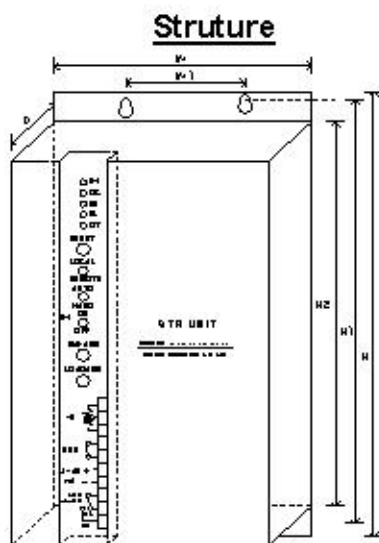

Size

Size(mm)	H	H1	H2	W	W1	D
Current(A)						
25~40	350	320	290	200	120	175
50~70	380	350	320	200	120	220
90~110	410	380	350	220	140	230
130~150	480	450	420	255	200	235
200~250	510	480	450	272	200	255
300~450	560	530	500	307	225	285
500~600	660	630	600	318	225	300
700~	Could be complied with customer's specification					
Remarks; The specification is subject to change without a prior to notice.						

Operation Parts and Function (Three Phase Unit)

Panel & Terminals	Name of operation parts	Function of operation parts
○ PW	Power LED	It turns on when the power selection switch on this control panel be switched on
○ OC	Over Current LED	It illuminates when an over current flows to heater, which is mainly caused by a short between the phases, and an earth between the phases and case
○ SP	Single Phase LED	It illuminates when high speed fuse be intercepted for an over current by short of the heater, and when the input power be failed.
○ SL	Single Load LED	It illuminates when the heater load deviation between phases exceeds 30 % or more, and when the heater element be cut or be as short.
○ OT	Over Temperature	It illuminates when the surface temperature of the Heat sink be abnormally higher, which is mainly caused by the cooling fan tripped.
⊙ RESET	Reset Button	This button is to manually restore the Unit when LEDs illuminate
⊙ LOCAL/REMOTE	Local/Remote selection switch	At "local mode" the heater is controlled by MAXAMP on this panel. At "remote" The heater is controlled by B10KW outside the Unit, or on heater panel.
⊙ AUTO/HAND	Auto/Hand selection switch	"Auto" is used when the heater is controlled by the TIC on heater panel. At "Hand" the heater is controlled by the MAXAMP on this panel.
⊙ PW ON/OFF	Power On/Off selection switch	This switch is to turn on or off the Unit or heater
⊙ MAXAMP	Max. Load Controller	This is used to limit the heater load at "local mode operation"
⊙ LOADAMP	OC alarm Point setter	This is used to set the over current alarming point.
	VR: Relay contacts of B10KW volume	At the Remote mode operation, this terminal is connected with the signal coming from B10KV volume outside the Unit
	RUN: Relay contacts of remote On/Off	Whenever turning on or off the heater at outside the Unit, this terminal is connected with the external on/off signal. While the power on/off switch on this panel must be turned off
	4~20mA : Relay contact of TIC control signal	At the Auto mode operation. This terminal is connected with the signal from TIC on the panel of the heater.
	Alarm : NC : Normal Close(B-Contact) NO : Normal Open(A-Contact) COM : Common	

Troubleshooting (Three Phase Unit)

⊙ In case S.P LED illuminates

- **When the High Speed Fuse is intercepted.**

- **In case a Resistive Load(heater).**

- A. Check if there is any short or damage in the heater. Usually almost 100% of troubles are caused by a short of the heater.
- B. Check if there is any loosened connection of each phase or short between phases at the output (U.V.W) of the Unit.
- C. Check if there is the damaged isolation between the output and case of the Unit.

- **In case an Inductive Load(transformer).**

- A. Check if there is any noise at input of the Unit.
- B. This interception is caused by a momentary power failure at the input of the Unit.

- **When the Control Fuse is intercepted.**

- Check if there is any damages in the control transformer.
- Check if the cooling fan is out of order.

⊙ In case O.C LED illuminates

- It illuminates when the LOADAMP volume is set at the level lower than the "Norm"
- It illuminates when there is the damaged isolation between the output and case of the Unit.
- It illuminates when there is the short between phases.
@ It may illuminate at the soft-start running time of the Unit.
- It illuminates when the LOADAMP volume does not properly work.
@ When the O.C LED illuminates, the output of the Unit stops and the Alarm Relay activates.

⊙ In case S.L LED illuminates.

- Check if there is any short in the heater and the current to each phase of the heater is uniform.
- Check if the CT(Current Transformer) is properly functioning.

⊙ When the Output is abnormal.

- Check if there is any incorrect connection at (+) and (-) of 4~20mA terminal on the control panel when the output is zero, even in case the output is 100% at "hand mode operation", or the heater is at "auto mode operation"
- Perform a Auto-Tuning of TIC at ambient temperature when the temp. difference between the its setting and the actual exceeds by 5 [°C].
- Check if the SCR of the Unit is burnt by an extra high temperature of the heat sink due to the fan failure. A damaged PCB may interrupt a normal operation of the Unit. The frequent short or electric leakage may cause SCR of the Unit burnt and cause PCB parts damaged too.
- Push the Reset Button to restore the system whenever above LEDs illuminate.
- The most important thing to keep the Unit out of the troubles is to clean the Unit out periodically and to check the tightness of every connections and contacts in the

Standard connection of 3 phase Thyristor Regulator

@ Hand(ON/OFF type)
(Internal volume)

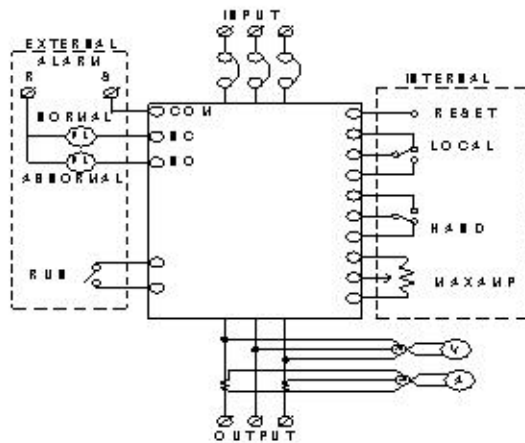

@ Hand(ON/OFF type)
(External volume)

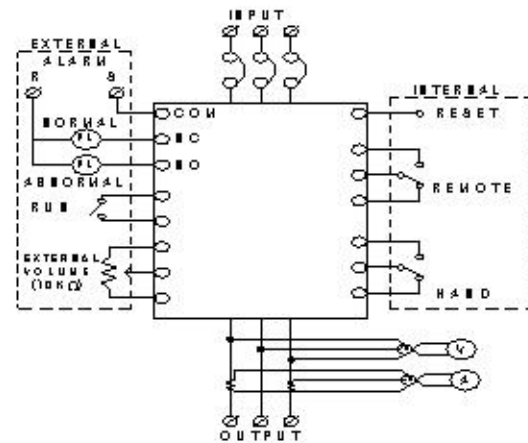

@ Auto(4~20mA Type)
(Internal volume)

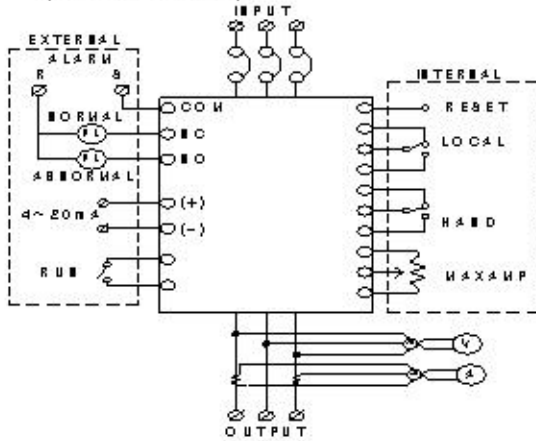

@ Auto(4~20mA type)
(External volume)

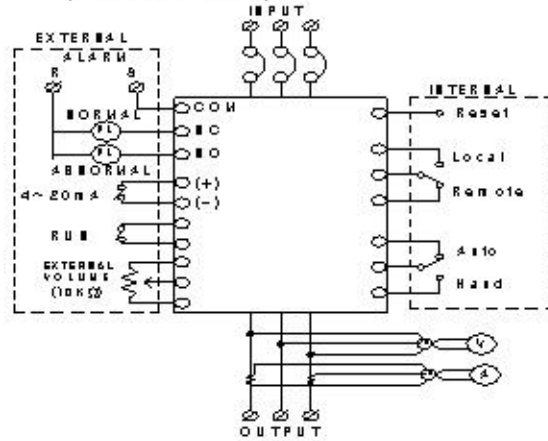

Block Diagram of Three Phase Unit

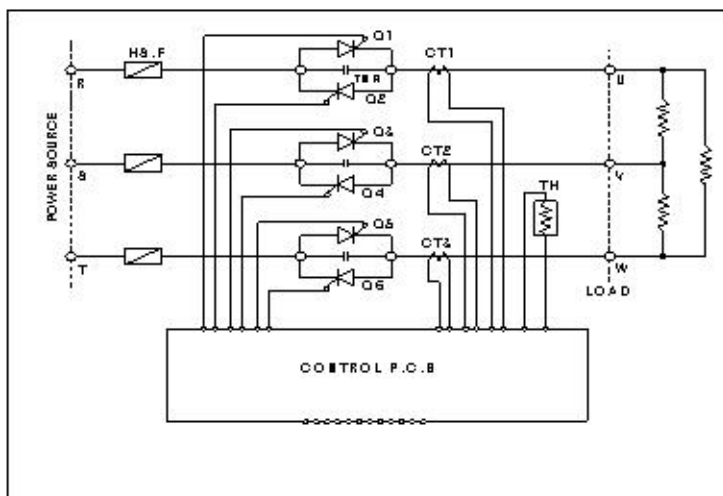

JA

@ In the left drawing, Q2, Q4 and Q6 can be replaced with the Diodes. But because its Voltage is not symmetric and is not a mean value (cf. the mean DC voltage of phases is zero), the Diodes can not be used in the inductive heater with magnetic circuit such as motor and transformer.

1Ø(Single Phase) Thyristor Regulator

Structure & Size

25 A~ 50 A9AL-Case)

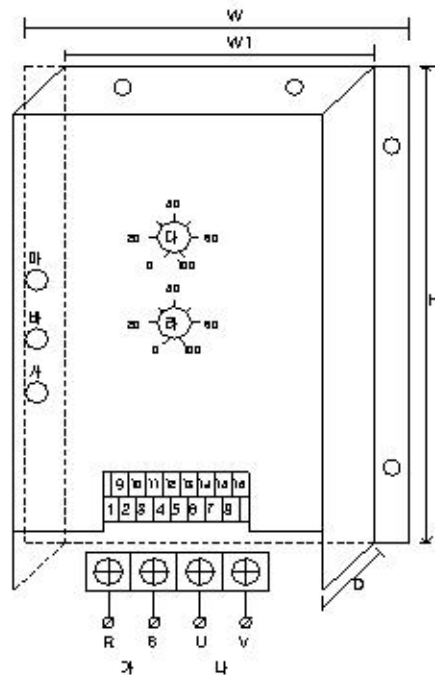

Control terminals(below 50A)

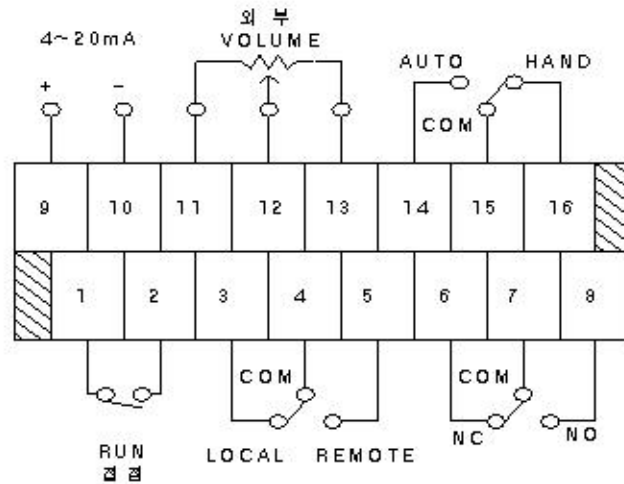

Control Parts and Function

Name	Function
Operation	
SFT: Data Setting Button (option)	It is used to set the initial control current or voltage.
PWR : Power LED	It illuminates when the power switch turns on .
Alarm(OC) LED	Red color : at Over-Current, Green color : at disconnection of the TIC4~20mA Yellow color : at disconnection of the heater.
MAXAMP Volume	It is used to set the the limit of Load.
LOADAMP Volume	It is used to set the alarming setting value of the Over Current.
R & S	Main Power Input connection the Unit
U & V	Main power Output connection to heater.
Terminals	
1 & 2 : Power Run terminal	Whenever turning on or off at outside of the Unit, this terminal is used to Connect with external ON/OFF signal.
3, 4 & 5 : Local/Remote selection terminal	1) Local is used to control the heater with MAXAMP Volume of the Unit. @Connect the COM & LOCAL together, 2) Remote is used to control the heater with the external volume(B10kΩ) at the pane @ Connect the COM & REMOTE
14, 15 & 16 : Auto/Hand SW selection terminal..	1) Auto is used to control the heater with the TIC output. (4~20mA) signal automatically. @ Connect the COM & AUTO together 2) Hand is used to manually control the heater with the MAXAMP Volume or external volume(B10kΩ) at the panel @ connect the COM & HAND together.
9 & 10 : 4~20 mA terminal.	This terminal is used to connect the 4~20 mA signal from TIC for the control of the Unit automatically .
11, 12 & 13 : External Volume terminal	This terminal is used to connect the external volume installed at the heater panel In order to control the Unit at remote position.
14, 15 & 16 : Alarm(OC) terminal signal	When the Unit is not working properly by an alarm among three colored alarms. It illustrates & activate the relay circuit to warn.

Steel Case(60A or higher)

Structure

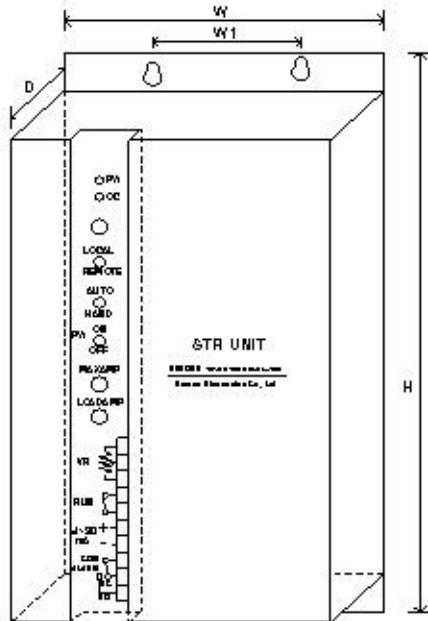

Size

Size(mm) Current(A)		H	W	W1	D
AL case	25~35	160	126	106	100
	40~50	205	126	106	100
steel case	60~70	290	145	120	150
	90~150	345	200	140	220
	200~250	450	210	150	235
	300~450	480	255	190	255
	500~	On customer's specification			

Operation Parts and Function (Single Phase Unit)

Panel & Terminals	Name of operation parts	Function of operation parts
○ PW	Power LED	It turns on when the power selection switch on this control panel be switched on
○ OC	Alarm LED	<ul style="list-style-type: none"> • Red color : In case Over-Current • Green color : In case 4~20mA signal is not coming from TIC • Yellow color : In case heater disconnection
⊕ RESET	Reset Button	This button is to manually restore the Unit when LEDs illuminate
⊕ LOCAL/REMOTE	Local/Remote selection switch	At "local mode" the heater is controlled by MAXAMP on this panel. At "remote" The heater is controlled by B10KW outside the Unit, or on heater panel.
⊕ AUTO/HAND	Auto/Hand selection switch	"Auto" is used when the heater is controlled by the TIC on heater panel. At "Hand" the heater is controlled by the MAXAMP on this panel.
⊕ PW ON/OFF	Power On/Off selection switch	This switch is to turn on or off the Unit or heater
⊕ MAXAMP	Max. Load Controller	This is used to limit the heater load at "local mode operation"
⊕ LOADAMP	OC alarm Point setter	This is used to set the over current alarming point.
	VR: Relay contacts of B10KW volume	At the Remote mode operation, this terminal is connected with the signal coming from B10KW volume outside the Unit
	RUN: Relay contacts of remote On/Off	Whenever turning on or off the heater at outside the Unit, this terminal is connected with the external on/off signal. While the power on/off switch on this panel must be turned off
	4~20mA : Relay contact of TIC control signal	At the Auto mode operation. This terminal is connected with the signal from TIC on the panel of the heater.
	Alarm :	NC : Normal Closed(B-Contact) NO : Normal Open(A-Contact) COM : Common

Troubleshooting (single phase Unit)

⊙ When the High Speed Fuse is intercepted.

• In case a Resistive Load(heater).

- Check if there is any short or damage on the heater. Usually almost 100% of troubles are caused by a short of the heater.
- Check if there is any loosened connection of the phase or a short at the output (U.V.) of the Unit.
- Check if there is the damaged isolation between the output and case of the Unit.

• In case an Inductive Load(transformer).

- Check if there is any noise at Input of the Unit.
- This interception is caused by a momentary power failure at the input of the Unit.

⊙ When O.C LED illuminates

- When the green color LED illuminates, check if the connection between 4~20mA signal and terminal on the control panel of the Unit is correct.
- When the red color LED illuminates :
 - Check if LOADAMP Volume is properly set at the position higher than the Over-Current "Norm".
 - Check if there is any damaged isolation between the output(U.V) and case of the Unit.
 - Check if the LOADAMP Volume is properly functioning.
 - @ If OC LED illuminates, the alarm circuit relay activates and then the Output stops.
- When the yellow color LED illuminates, check if there is any short or disconnection in the heater. Also check if the heater load deviation exceeds by 20% or higher than its initial setting value..

⊙ When the Output is abnormal.

- Check if there is any incorrect connection at (+) and (-) of 4~20mA terminal on control panel of the Unit when the output is zero, even in case the output is 100% at "hand mode operation" or the heater is at "auto mode operation"
- Perform a Auto-Tuning of TIC at ambient temperature when the temperature difference between the its setting and the actual exceeds 5 [C] .
- Check if the SCR of the Unit is burnt by an extra high temperature of heat sink due to the fan failure.
- A damaged PCB may interrupt a normal operation of the Unit. The frequent short or electric leakage may make SCR of the Unit burnt and causes PCB parts damaged
- The most important thing keeping the Unit out of the trouble is to clean the Unit out periodically and to check the tightness of every connection and contact in the Unit.

Standard connection of Single Phase STR-Unit

@ Auto(4~20mA) operation
(internal volume)

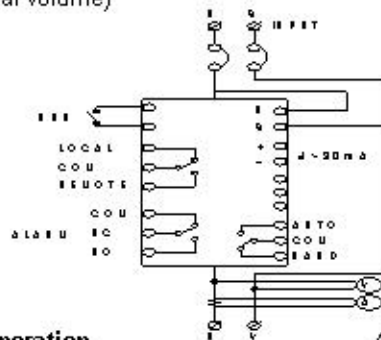

@ Auto(4~20mA) operation
(external volume)

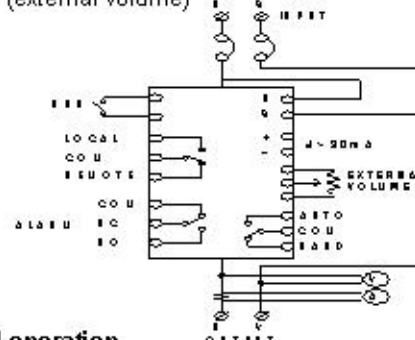

@ Hand operation
(internal volume)

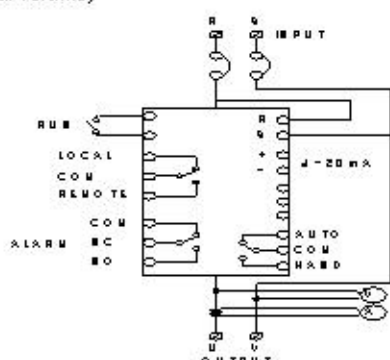

@ Hand operation
(external volume)

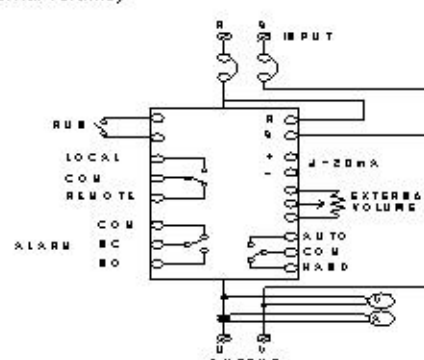

Internal connection of single phase STR-Unit

